

# QMC Series Railcar Vibrators

**Need Help Now?**

Call 800-842-7284 or visit  
[www.ChicagoVibrator.com](http://www.ChicagoVibrator.com)

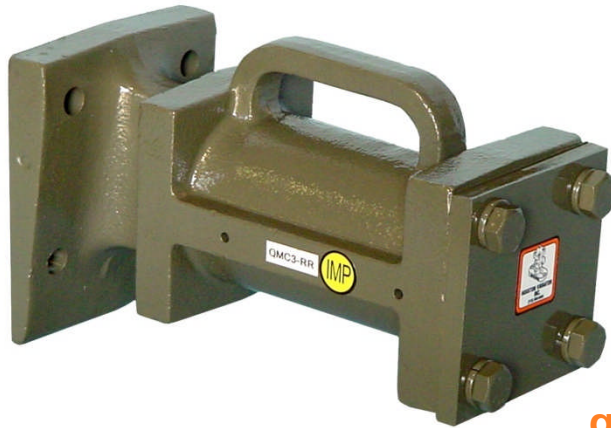

**We made it lighter.  
Not weaker.**

Let the QMC lighten the  
load on your back while it  
quickly unloads your railcars

## QMC Series Linear Pneumatic Railcar Vibrators

QMC Series linear pneumatic piston railcar vibrators provide powerful linear force to speed up railcar unloading. The force output is the same as our popular HCV-312 models, but at 54 pounds, the QMC is 22 pounds lighter.

The weight reduction is accomplished using a one-piece casting with integral wedge head, rather than the traditional two-piece design. This not only reduces the weight of the unit, making it much easier to handle, but also eliminates the possibility of wedge head bolts loosening.

The QMC-3 RR is available in Impacting or Air Cushioned configurations. For the most forceful impact, choose an Impacting model. Where quiet operation is important, choose the Air Cushioned (non-impacting) model.

### Standard features & benefits

- CNC Machined bodies & pistons ensure reliable operation
- Force & frequency are adjustable by varying supply air pressure
- Efficient operation - uses less air than rotary vibrators with comparable force
- Universal wedge head mount fits standard dovetail brackets on cars
- Low maintenance when installed with proper air-prep components

### Available options & accessories

- Internal Tefkote for lubrication-free operation
- HCV Cart makes vibrators easier to move and place on car
- Hose Control Assembly ensures automatic lubrication and puts controls close at hand

Houston Vibrator can also provide these products for your facility:

- LIFT Series Hopper Car Unloading Lifts for containing material during transfer from railcar to pit conveying system
- Pneumatic & electric vibrators for truck-loading spouts
- Pneumatic & electric vibrators for storage bins and tanks
- Dust Collector & Bag House vibrators

# QMC Series Technical Data

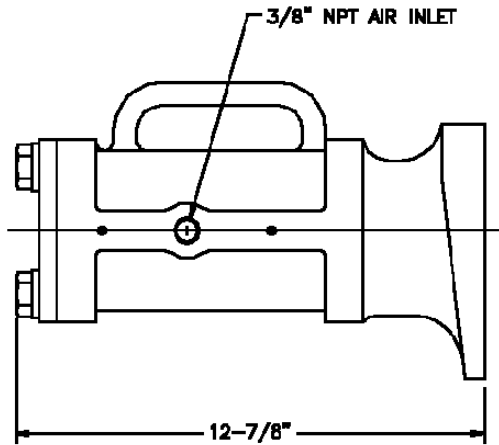

Model	Force Lbs		Frequency VPM		Air Consumption CFM		Weight		Air Inlet
	@60 PSI	@80 PSI	@60 PSI	@80 PSI	@60 PSI	@80 PSI	Lbs	Kgs	NPT
QMC3-RR IMP	1203	1558	2900	3300	10.5	11.5	52	23.6	3/8
QMC3-RR AC	329	456	1550	1825	10.2	13.0	52	23.6	3/8

## Components and Accessories



A Hose Control Assembly puts controls where you need them - at the vibrator. One end connects to the air source with a crow's foot connector, and the other end includes a male fitting to connect to your vibrator. The in-line lubricator continually lubricates the vibrator to decrease wear and tear, and manual lever valve allows on/off control of vibrator.



Lubro-Control units allow regulation of air pressure, and keep supply air clean and lubricated to increase the service life of your railcar vibrator. Air prep components are available in several different sizes and configurations.



The HCV Cart reduces operator strain by doing the heavy lifting for you. The cart can be used with any HCV or QMC model. Simply place the vibrator on the cradle, and wheel the cart and vibrator into position. Lower the vibrator into the dovetail bracket on the car, and you're ready to go. Custom sizes are available.

The Houston Vibrator Sales Team is available to assist you in choosing the model and accessories that best suit the material you unload, and the requirements of your facility. Contact us today for assistance.

Distributed By:

**ChicagoVibratorProducts**  
Flow and Compaction

Division of CVP Group  
800-842-7284 (P)  
866-247-7538 (F)

Solutions@ChiVib.com  
www.ChicagoVibrator.com

